



INNOVATIVE DESIGNS
FOR CREATIVE SPACES.

T-Leg Table LP45 Leg & Stretcher Assembly Instructions

Tools Required for Assembly:

- 3/8" Ratchet with 3" Extension
- 9/16" Socket and 9/16" Combination Wrench
- Philips Head Screwdriver - OR - Cordless Drill with #2 Phillips Bit

Included Parts and Hardware:

4 x 3/8" Hex Bolts 1 3/4" Long

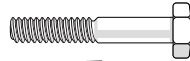

4 x 3/8" Flat Washers



4 x 3/8" Hex Nuts



4 x 1/2" Pan Head Phillips Machine Screws



4 x 3/8" Lock Washers



8 x 3/4" Phillips Head Wood Screws



2 x Leg Uppers

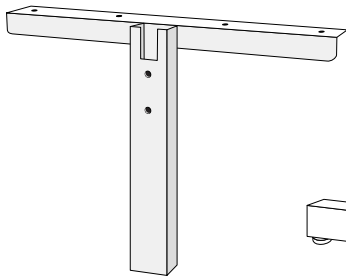

2 x Leg Bases

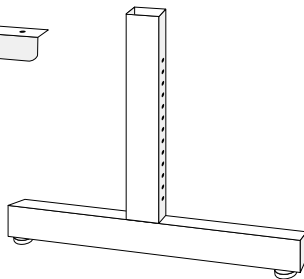

1 x Stretcher

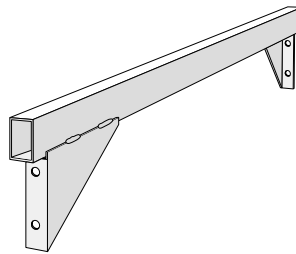

1 x Table Top

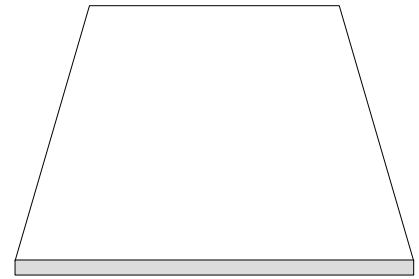

Step 1

Place the table top-side-down on a soft surface to prevent scratching. The flattened shipping carton is ideal for this purpose.

Pre-assemble the T-Legs by sliding the black upper section over the chrome base. Set legs to the desired height (remembering that the top will add 1-1/4").

Secure with two Phillips head machine screws.

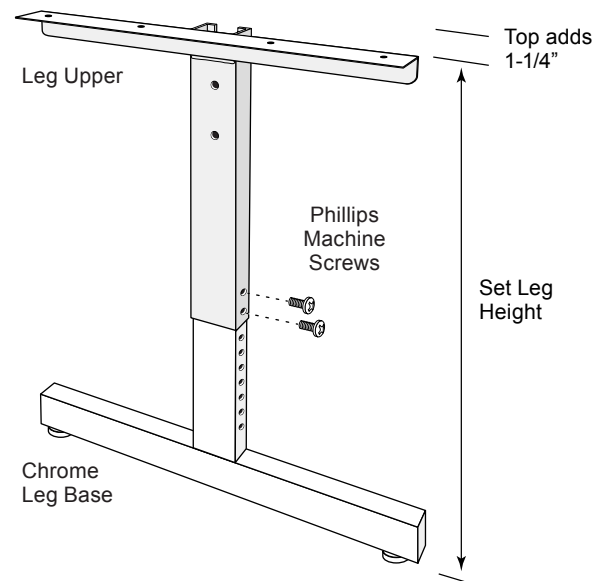

T-Leg Table

Assembly - continued

Step 2

Insert one end of the stretcher into the notch at the top of the leg assembly.

Install bolts with flat washers through the leg and bracket, then finger tighten the split washers and nuts.

Repeat for other end.

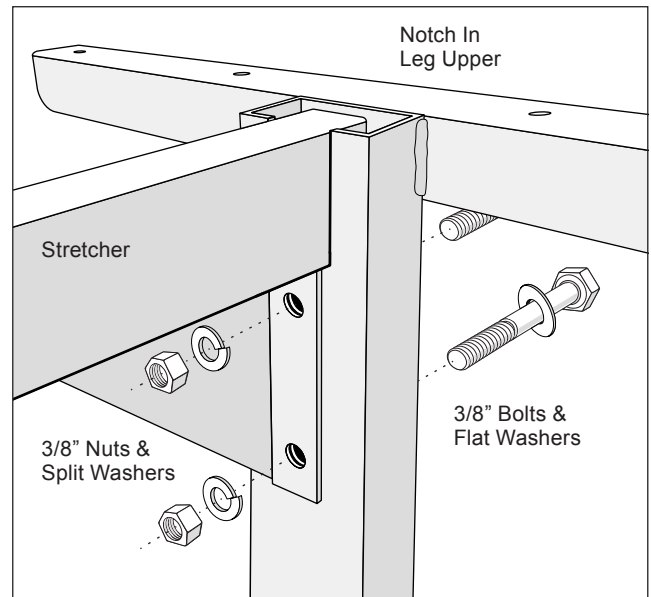

Step 3

Position the assembly over the pre-drilled holes in the table top. Install all 8 Phillips head wood screws completely. Complete assembly by fully tightening the 3/8" bolts.

With a helper, turn the table upright and enjoy years of sturdy, reliable service from your new Allied table.

